

Pedido:

Módulo de base aberto modular

Modelo: S150050

Medidas: 360x600x650mm

Item:

Qtd:

DESENHO TÉCNICO/INSTALAÇÃO

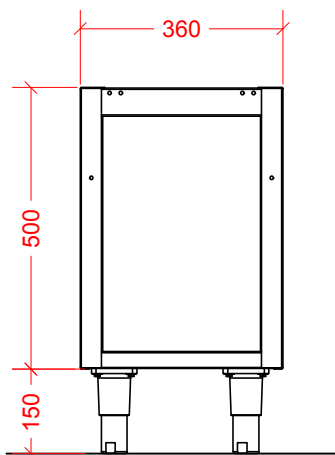

Frontal

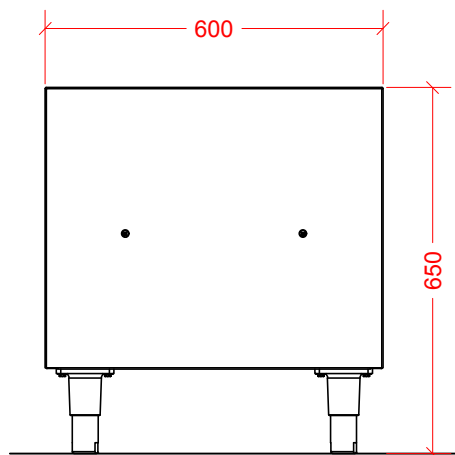

Lateral

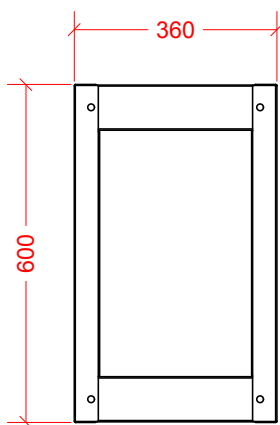

Superior

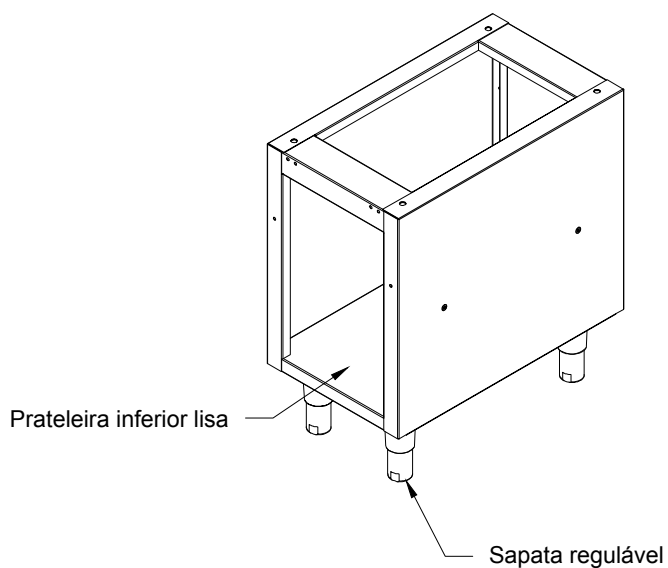

ESPECIFICAÇÃO TÉCNICA

Construído em aço inoxidável, possui frente aberta e pés com nivelamento de altura.